



mQuvée



VELVET 125 GLASS

- mQuvée wine storage cabinet

PRODUCT SPECIFICATION

- Can be built in or used as a free-standing unit.
- 1 adjustable temperature zone (5-22 °C)
- Multiple layout variants for your preferences
- Compressor cooling
- Humidity control
- Seamless door
- Reversible, UV-protected glass door

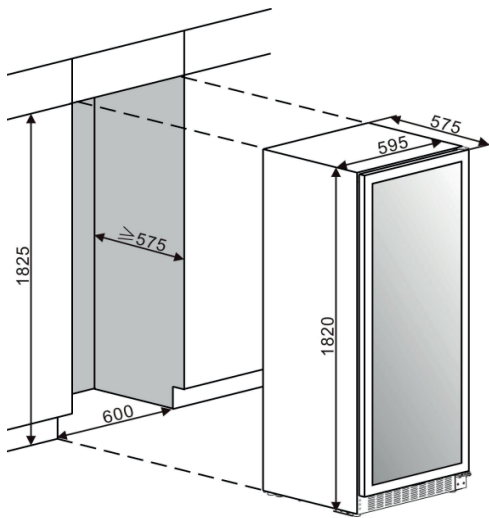

SIZE AND DIMENSIONS

- Dimensions: (Width x Height x Depth)
59.5 x 182/189 x 57.5 cm
- Weight: 89 kg
- Space for about 200 bottles

OTHER SPECIFICATIONS

- Adjustable humidity
- Winter Safety
- Carbon filter
- ON/OFF-for electricity
- Concealed front ventilation
- LED-lighting with ON/OFF- button
- Touch-control panel
- Alarm for low/high temperatures
- Alarm for open door

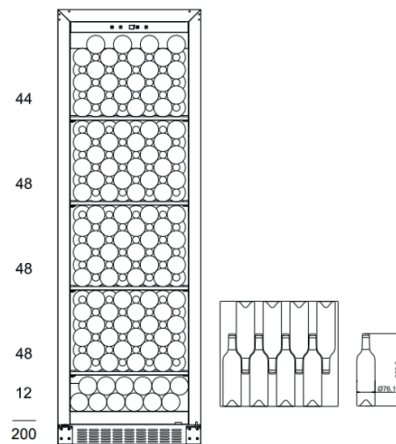

AVAILABLE IN:

Fullglass Black



TECHNICAL DATA

- Voltage: 220-240 V
- Noise level: 41 dB (A)
- Energy class: G
- Climate class: SN | ST
- Effect: 160 W
- Annual power consumption: 170 kWh