



mQuvée



WINECAVE 187

- mQuvée built-in wine cooler

PRODUCT SPECIFICATION

- Can be built-in in your kitchen or free-standing
- 2 adjustable temperature zones (5-20 °C)
- Sliding wood shelves
- Compressor cooling
- Fan assistance for balanced temperature
- Seamless-door (*no joints*)
- Reversible, UV-protected glass door

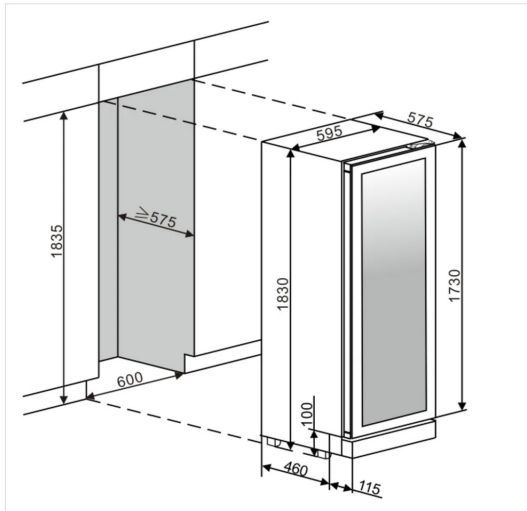

SIZE AND DIMENSIONS

- Dimensions: (Width x Height x Depth)
59.5 x 183/190 x 57.5 cm
- Weight: 104 kg
- Space for about 115 bottles

OTHER SPECIFICATIONS

- Automatic defrosting
- Winter safety
- ON/OFF-for electricity
- Adjustable feet 8 cm
- LED-lighting with ON/OFF- button
- Digital display for temperature (white)
- Touch-control panel
- Alarm for low/high temperatures
- Alarm for open door

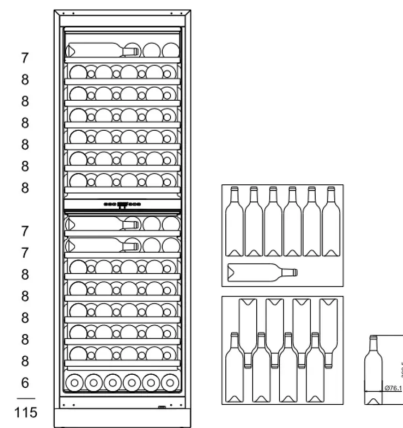

AVAILABLE IN:

Stainless



Anthracite black



TECHNICAL DATA

- Voltage: 220-240 V
- Noise level: 36 dB (A)
- Energy class: G
- Climate class: ST
- Effect: 160 W
- Annual power consumption: 170 kWh