



mQuvée

## WINEKEEPER 25D

- mQuvée integrated wine cooler



### PRODUCT SPECIFICATION

- Can be wholly built-in and integrated
- 2 adjustable zones (*5-22 degrees*)
- 3 pull-out wooden shelves (*beechwood*)
- Compressor-based cooling system
- Fan cooling for balanced temperature (interior)
- Seamless-door (*without joins*)
- UV-protected glass door

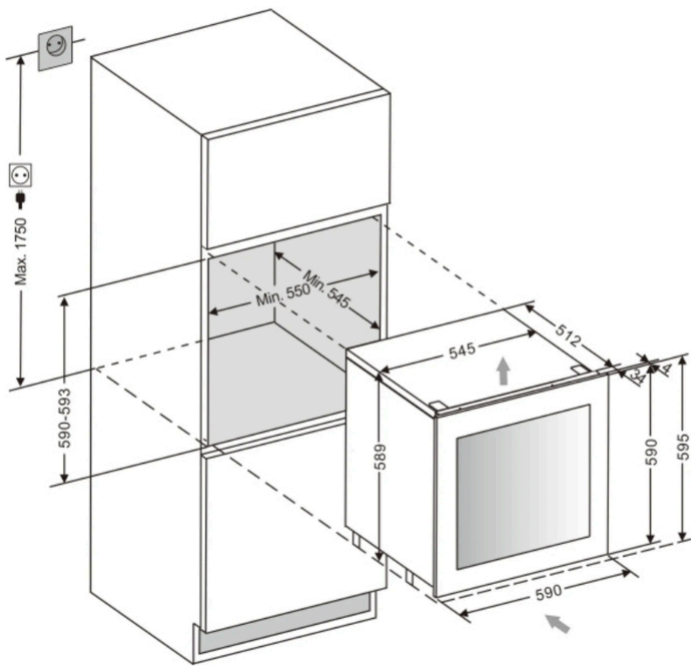

**SPACE FOR 26 BOTTLES**

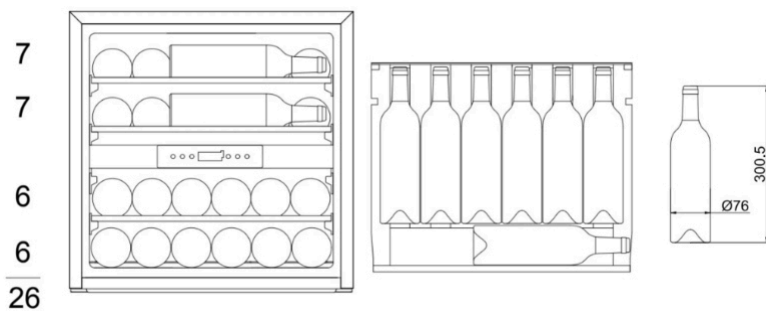

### OTHER SPECIFICATION

- Low vibration for perfect storing your wine bottles
- Automatic defrosting
- Winter safety
- Carbon filter
- Water container for additional adjustment of humidity
- ON/OFF-for electricity
- Adjustable feet 1 cm
- LED-lighting with ON/OFF- button
- Digital display for temperature (white)
- Touch-control panel in wine cooler
- Alarm for low/high temperatures
- Alarm for open door

### SIZE AND DIMENSIONS

- Dimensions: (*Width x Height x Depth*)  
59 x 59,5 x 55 cm
- Weight: 32 kg
- Space for 26 bottles

### AVAILABLE IN

Stainless steel

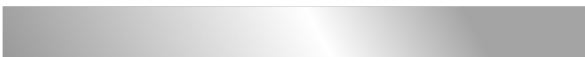

Anthracite



Custom made



### TECHNICAL DATA

- Voltage: 220-240 V
- Climate class: SN-ST
- Effect: 100 W
- Annual power consumption: 99.0 kWh
- Energy class: F
- Noise level: 39.0 db(A)