



mQuvée



## WINECAVE 50D | 700

- mQuvée built-in wine cooler

### PRODUCT SPECIFICATION

- Can be built-in under your kitchen counter or free-standing
- 2 adjustable zones (*5-20 degrees*)
- 5 pull-out wooden shelves (*beechwood*)
- Compressor cooling
- Fan cooling for balanced temperature
- Seamless-door (*door without joins*)
- UV-protected glass door
- Reversible glass door

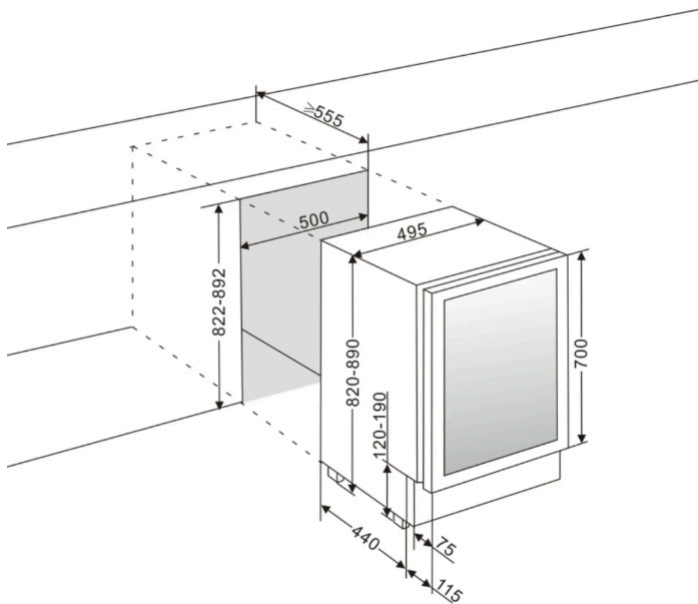

## SPACE FOR 39 BOTTLES

### OTHER SPECIFICATION

- Low vibration for perfect storing your wine bottles
- Automatic defrosting
- Winter safety
- Carbon filter
- Water container for additional adjustment of humidity
- ON/OFF-for electricity
- Adjustable feet 7 cm
- LED-lighting with ON/OFF- button
- Digital display for temperature (white)
- Touch-control panel in wine cooler
- Alarm for low/high temperatures
- Alarm for open door

### SIZE AND DIMENSIONS

- 700 mm door height
- Dimensions: (*Width x Height x Depth*)  
49,5 x 82/89 x 55.5 cm
- Weight: 43 kg
- Space for 39 bottles

### TECHNICAL DATA

- Voltage: 220-240 V
- Noise level: 36 dB (A)
- Energy class: F
- Climate class: SN-ST
- Effect: 100 W
- Annual power consumption: 101.0 kWh

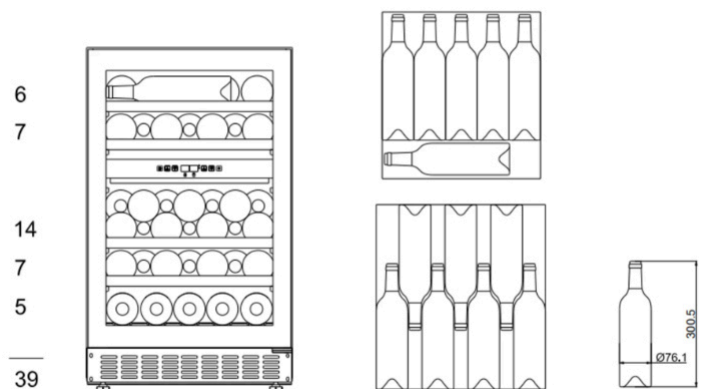

### AVAILABLE IN

Stainless steel



Modern



Anthracite black



Custom Color

